

DETAIL OF 'ch1a' (AS SHOWN)  
SCALE: 1 1/2"=1'-0"

DETAIL OF 'ch2a' (OPP. HAND)  
SCALE: 1 1/2"=1'-0"

8SA' - STAIR ASSEMBLY - ONE REQUIRED  
SCALE: 1"=1'-0"

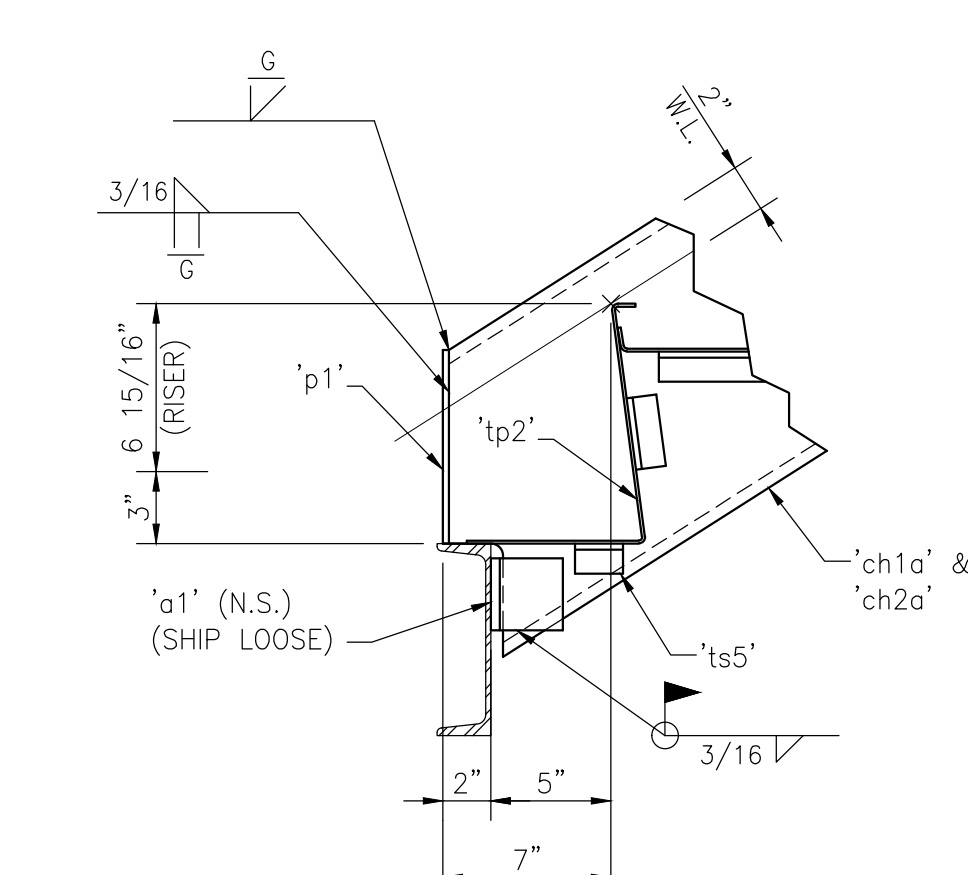

DETAIL 'A'  
SCALE: 1 1/2"=1'-0"

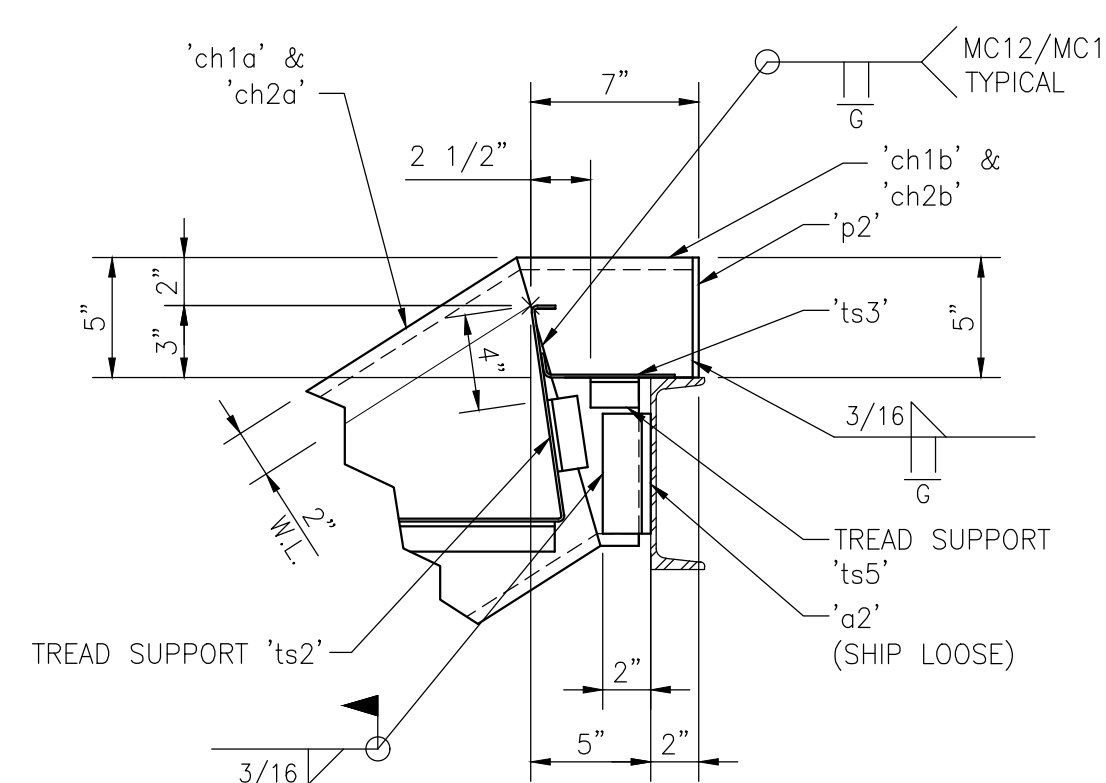

DETAIL 'B'  
SCALE: 1 1/2"=1'-0"

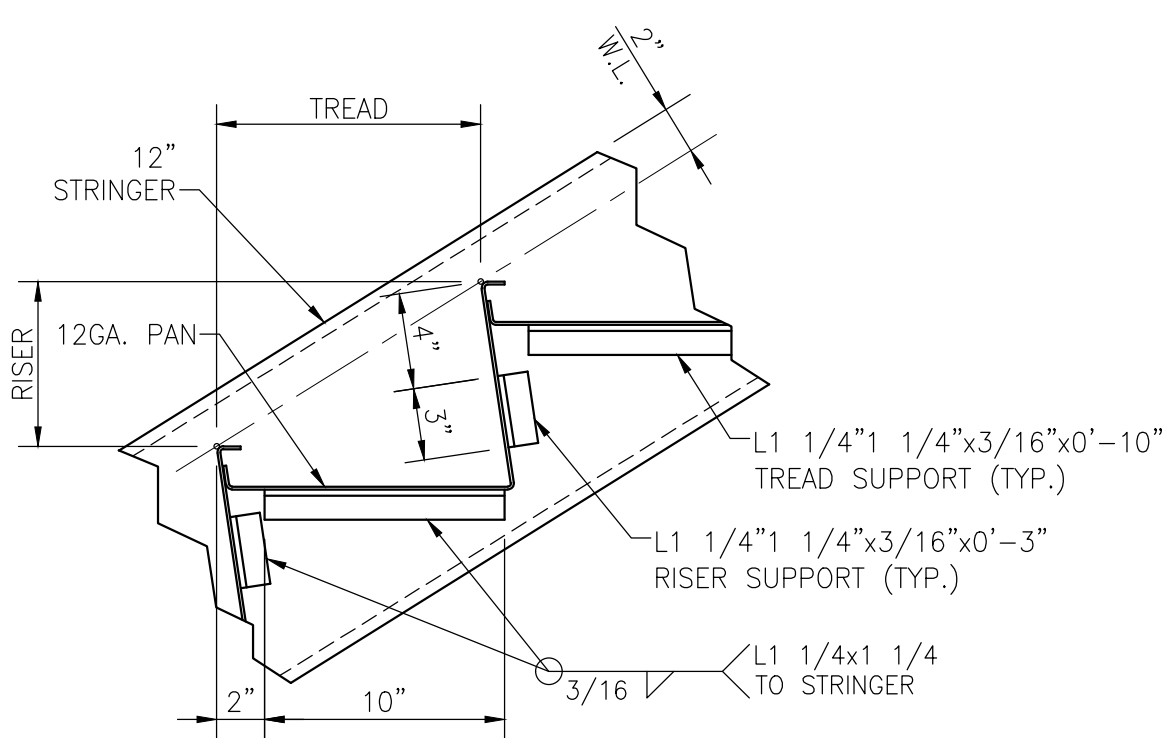

TYPICAL TREAD SUPPORT ANGLE LOCATION  
SCALE: 1 1/2"=1'-0"

BILL OF MATERIAL				
MATERIAL LISTED FOR ONE UNIT OR ASSEMBLY				
PART NO.	NO. REQ.	DESCRIPTION	MAT'L.	REMARKS
8SA - STAIR ASSEMBLY - ONE REQUIRED				
ch1a	ONE	MC12 x 10.6 x 10'- 9 5/16"	A36	SEE DETAIL THIS DWG.
ch2a	ONE	MC12 x 10.6 x 10'- 9 5/16"	A36	SEE DETAIL THIS DWG.
ch1b	ONE	MC12 x 10.6 x 0'- 7 5/16"	A36	SEE DETAIL THIS DWG.
ch2b	ONE	MC12 x 10.6 x 0'- 7 5/16"	A36	SEE DETAIL THIS DWG.
a1	2	L 3 x 3 x 3/8 x 0'-3" (SHIP LOOSE)	A36	
a2	2	L 3 x 2 x 3/8 x 0'-5" (SHIP LOOSE)	A36	
p1	2	PL 1/4" x 1 1/2" x 0'-8"	A36	
p2	2	PL 1/4" x 1 1/2" x 0'-5"	A36	
ts1	18	L 1 1/4 x 1 1/4 x 3/16 x 0'-10"	A36	
ts2	22	L 1 1/4 x 1 1/4 x 3/16 x 0'-3"	A36	
ts5	4	L 1 1/4 x 1 1/4 x 3/16 x 0'-2"	A36	
tp1	9	PLATE 12 GA. x 22 1/4" x 3'-6" (BENT)	A36	SEE DETAIL THIS DWG.
tp2	ONE	PLATE 12 GA. x 18 1/2" x 3'-6" (BENT)	A36	SEE DETAIL THIS DWG.
tp3	ONE	PLATE 12 GA. x 6 1/2" x 3'-6" (BENT)	A36	SEE DETAIL THIS DWG.

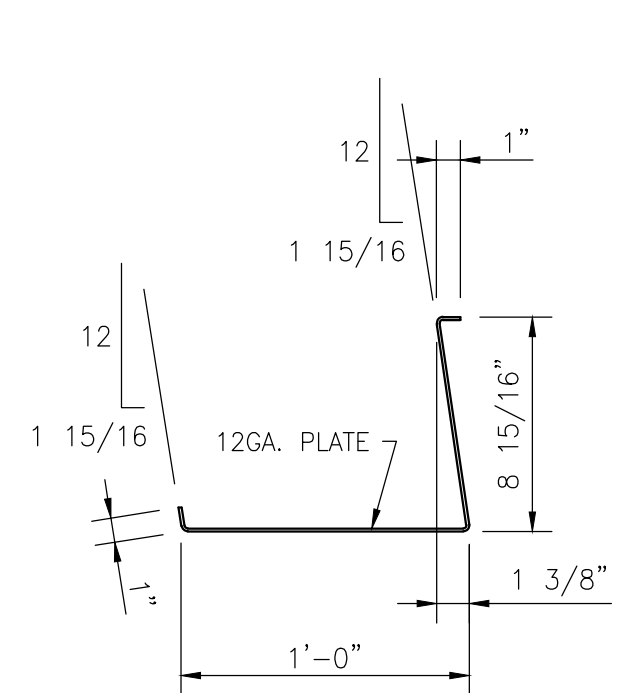

DETAIL OF 'tp1'  
SCALE: 1 1/2"=1'-0"

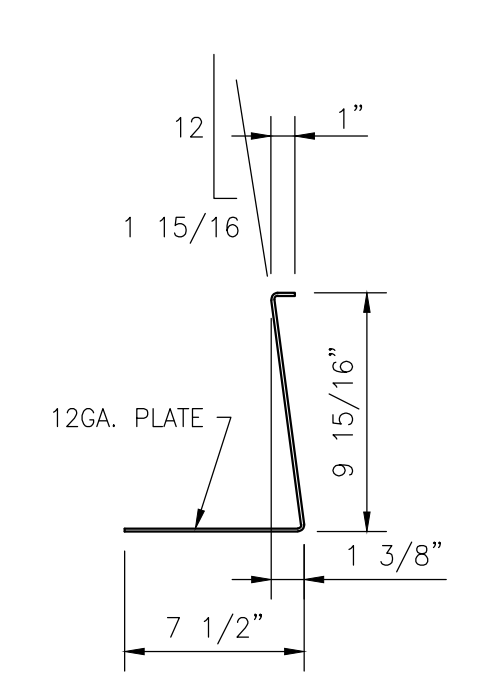

DETAIL OF 'tp2'  
SCALE: 1 1/2"=1'-0"

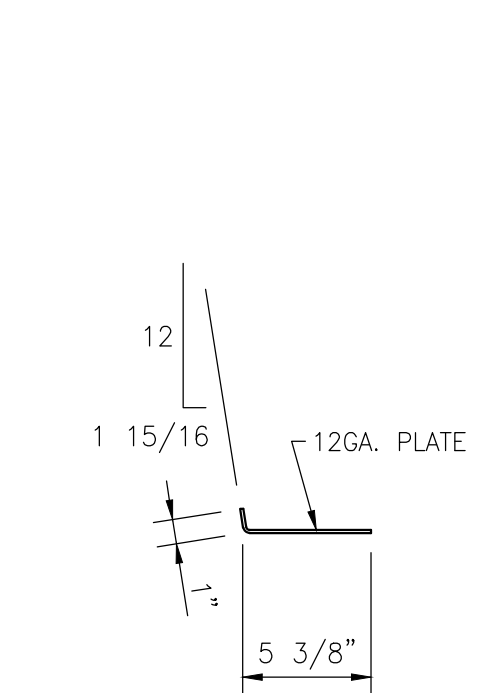

DETAIL OF 'tp3'  
SCALE: 1 1/2"=1'-0"

ALL MATERIAL SHOWN ON THIS DRAWING SHALL RECEIVE ONE COAT OF STANDARD SHOP PRIMER U.N.O.

STAIR A		PROJECT NUMBER	
FABRICATION DETAILS		21-175	
DRAWN BY: KSB	CHECKED BY: TS	SD-8	
ISSUE FOR FABRICATION	ISSUED BY:		
NO. DATE	REVISION DESCRIPTION		

2			
1			
0	5/24/22	ISSUE FOR FABRICATION	TS
NO.	DATE	REVISION DESCRIPTION	ISSUED BY